

# Packs - Turning Cross

Type GDK - 90

## Your Benefits

- high output increases your product efficiency
- precise and gentle 90°- turning
- suitable to different sizes of packs
- low-maintenance and wear-resistant due to the qualitative construction
- durable despite permanent operation
- minimum space requirement
- quick assembly and commissioning

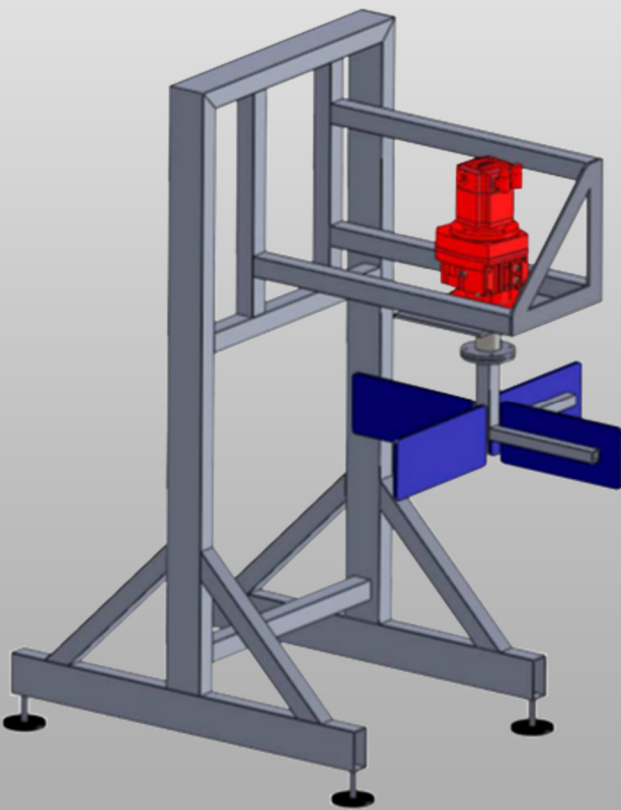

## General

The Packs – Turning Cross is suitable for the **accurate 90 degree turning** of different products like cartons, shrink-packs, soft-packs, crates and many other.

In particular, small and very low products can be turned by our **powerful turning system**. The Turning Cross is also applied when the gap between the products is very small.

Our Packs – Turning Cross has a high durability due to the **qualitative processing**.

Because of the **compact and robust form** the Turning System is space-saving and can be retrofitted during operation.

► **Output: up to 6,000 packs / h**

## Function

The packs – turning cross type GDK – 90 is installed above or next to the conveyor depending on the space conditions and it moves over the conveyor belt.

The system consists of a turning mechanism with four plastic wings that are driven by one **SEW-Servo-Drive**. Thereby the turning mechanism rotates repeatedly in one direction.

In the functional sequence, a product runs to the pack - turning cross, is captured laterally by a plastic wing that is parallel to the product and is turned gently by 90 degrees. After the rotation, a new plastic wing is available for the next execution and the product runs further in changed position.